

# Servo Linear RC Actuators

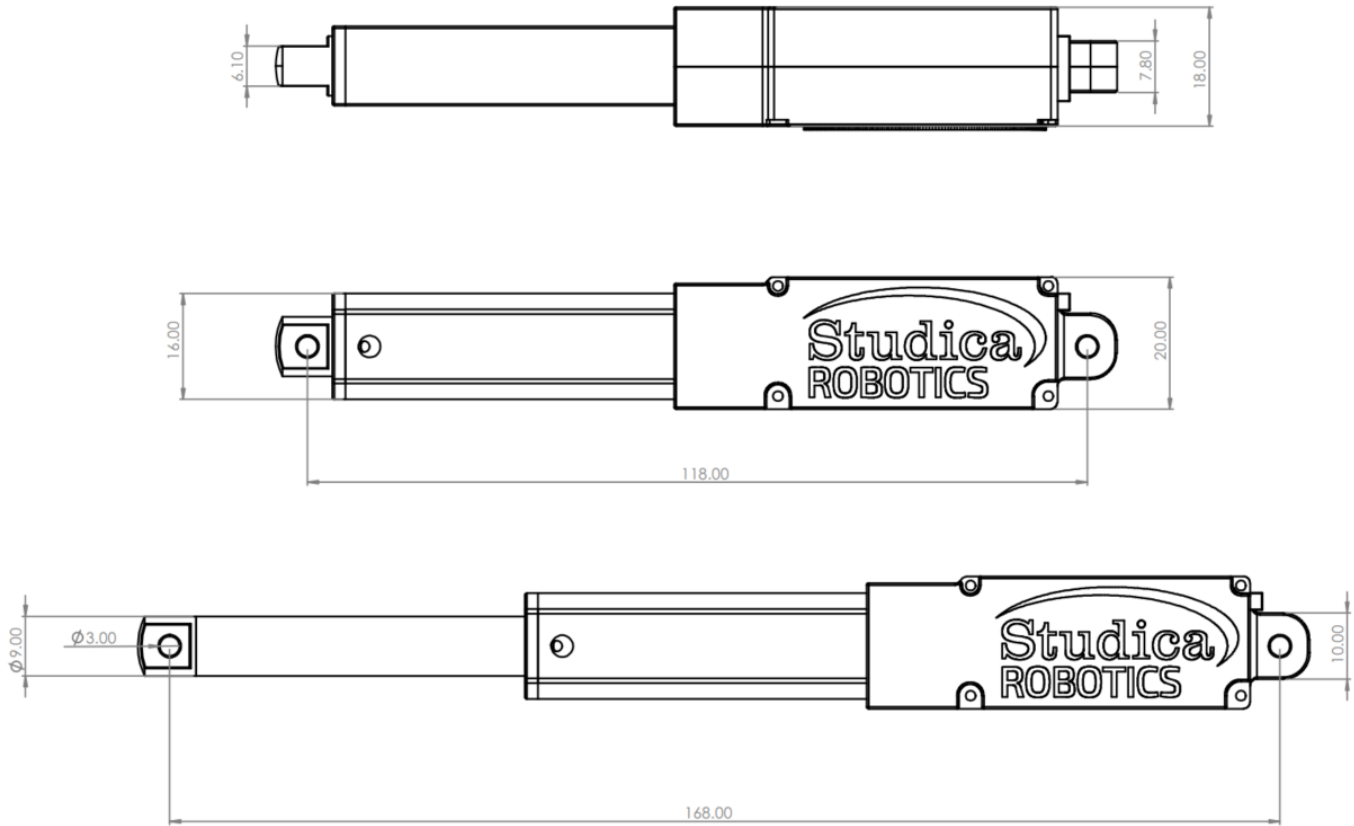

Part #		75010 50S-95N (Min 250)	75011 50S-190N	75012 50S-40N	75013 140S-95N (Min 250)	75014 140N-190N	75015 140S-40N
Control Signal		PWM	PWM	PWM	PWM	PWM	PWM
Frequency (Hz)		50	50	50	50	50	50
Voltage (VDC)		6	6	6	6	6	6
Stroke Length (mm)		50	50	50	140	140	140
Gear Ratio		63:1	150:1	36:1	63:1	150:1	36:1
No Load	Speed (mm/s)	13	6	24	13	6	24
	Current (mA)	150	150	150	150	150	150
Max Efficiency Point	Load (N)	30	75	16	30	75	16
	Speed (mm/s)	11	5	20	11	5	20
	Current (mA)	360	360	360	360	360	360
Peak Power Point	Load (N)	66	170	30	66	170	30
	Speed (mm/s)	8	3.3	17	8	3.3	17
	Current (mA)	560	560	560	560	560	560
Max Force	Load (N)	95	190	40	95	190	40
	Speed (mm/s)	5	2.5	14	5	2.5	14
	Current (mA)	850	820	620	850	820	620
Stall Torque (N)		150	325	50	150	325	50
Stall Current (A)		1	1	1	1	1	1
Max Static Force (N)		100	190	40	100	190	40
Weight (g)		65	65	65	96	96	96
Stroke Repeatability (mm)		±0.5					
Max Side Load (N)		10					
Operating Temperature Range (°C)		-10 ~+50					
Storage Temperature Range (°C)		-10 ~+50					
Wire Length (mm)		340					
Connector		2.54mm Dupont 3-Pin Female					

## 50mm Stroke Length Drawing



## 140mm Stroke Length Drawing

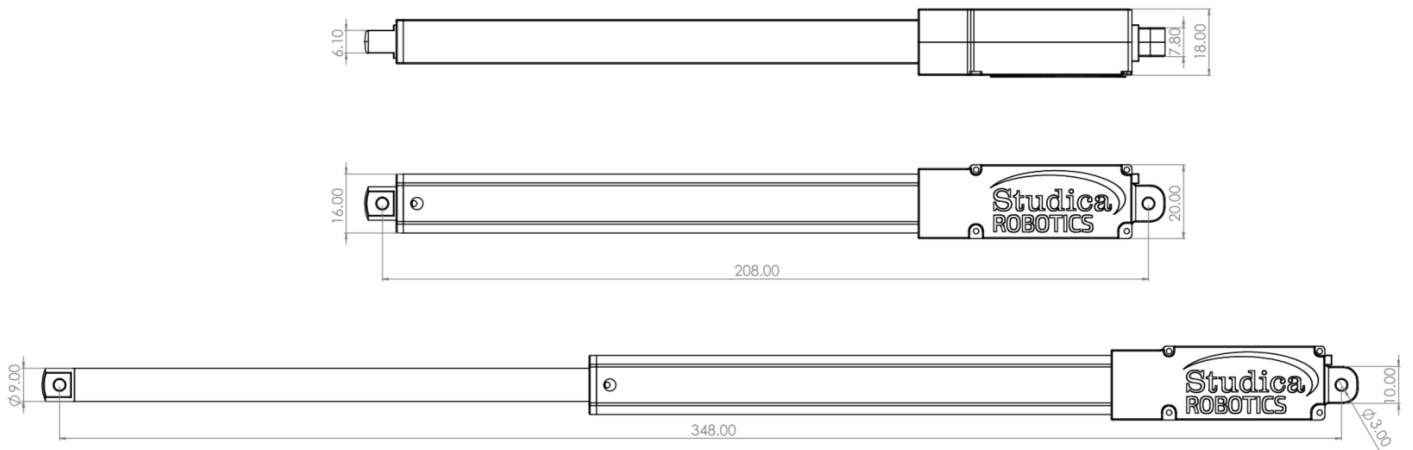

## Pulse Width Range

The linear servos have a different pulse width range than that of normal servos. The range of a normal servo is generally  $500\mu\text{s}$ . to  $2500\mu\text{s}$ . The linear servo has a standard range of  $900\mu\text{s}$  to  $2100\mu\text{s}$ . However, due to tolerances in control, this range generally needs to be manually calibrated per linear servo.



At full retraction, the pulse width should be around  $900\mu\text{s}$ . Observational measurements have found this value to be between  $850\mu\text{s}$  and  $1000\mu\text{s}$ .



At full extension, the pulse width should be around  $2100\mu\text{s}$ . Observational measurements have found this value to be between  $1890\mu\text{s}$  and  $2150\mu\text{s}$ .